



# Next Steps in MSDL and C-BML Alignment for Convergence

Dr. Mark Pullen  
Douglas Corner  
GMU C4I Center

Dr. Robert Wittman  
MITRE Corp.

# Presentation Overview

- Introduction/overview
- MSDL and C-BML alignment
- Implementation
  - 9LandBMS
  - OneSAF
  - WISE-SBML
- Way forward for MSG-085 and MSDL/C-BML

# Introduction/Overview

- Goal: interoperation of C2IS with simulations
  - Shown by MSG-048 to have high potential value
  - Coalition training, COA evaluation, mission rehearsal
  - A focus of Simulation Interoperability Standards Organization
- Military Scenario Definition Language (MSDL)
  - Standardizes initialization of simulation systems
  - Recently shown also to be useful with C2 systems
- Coalition Battle Management Language (C-BML)
  - Orders, Requests, and Reports among C2 systems / simulations
  - Building block: Task (who/what/when/where/why) + its status
  - Intended for use by international coalitions
- The two must work together
  - This paper addresses a mechanism for their convergence

# MSDL Background

- Grew out of need in US Army OneSAF program
  - Reduce scenario development time
  - Re-use resulting scenarios
- XML-based military scenario format
  - Designed for use by current and evolving simulations
  - Prototyped within OneSAF 2001-2004
  - Spawned SISO Study Group
  - Product Development Group chartered 2006
  - SISO MSDL v1.0 standard approved 2008

# Why Use MSDL Data Format

## Import Format versus Native Format

- Allows MSDL and specific simulation initialization native formats to evolve at their own appropriate pace.
- Allows simulations to define specific information needs.
- Allows consistent scenario starting point for specific simulation initialization

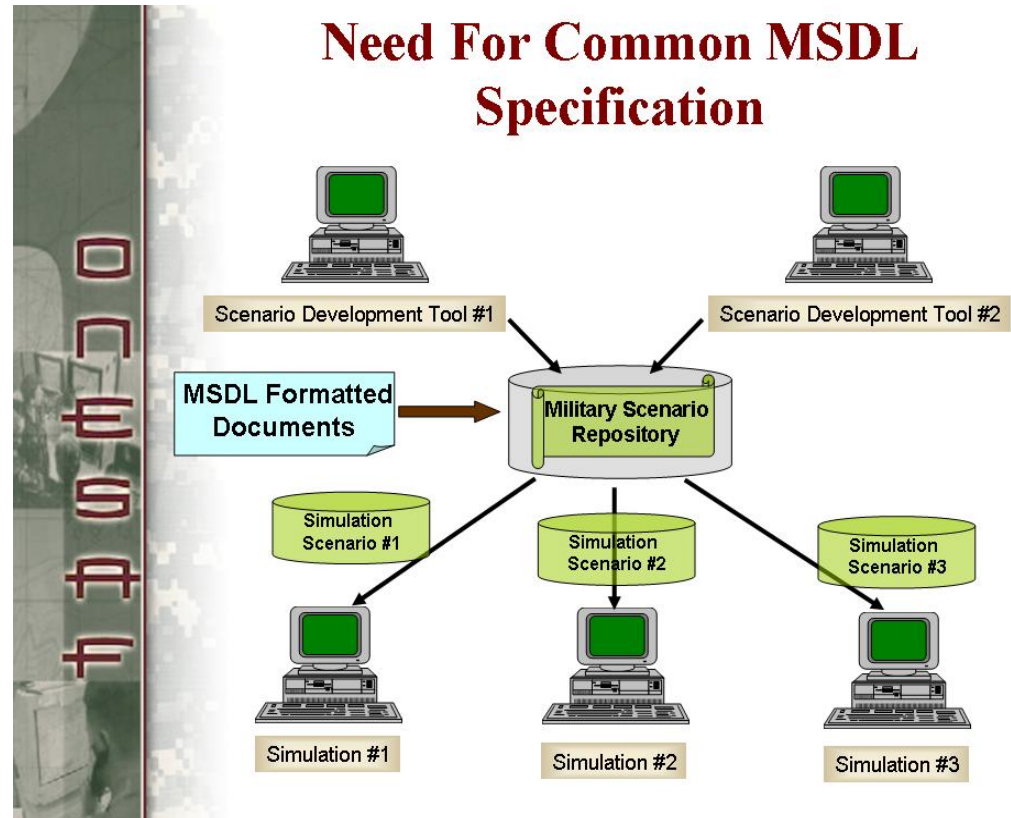

# MSDL Data Components

- Geographic Region of Interest
- Force/Sides
- Units
- Equipment
- Installations
- Overlays
- Graphics
- Military Operations Other Than War

# BML: Definition

BML - an unambiguous language to:

Command and control live and simulated forces conducting military operations, and

Provide for situational awareness and a shared, common operational picture.

*Shared Semantics between C2 and M&S via a Common Tasking Description*

# C-BML Background

- Purpose: provide a common, agreed-to format for exchange of Orders/Requests/Reports between C2 and simulation systems
- Implemented using a repository where participating systems post and retrieve XML documents
  - Extended to publish/subscribe for efficiency
- SISO study group 2005
- Product development group chartered 2007
  - Phase 1 Standard package balloted 2012
- Development informed by NATO Technical Activities MSG-048 and MSG-085

# Generic BML Architecture

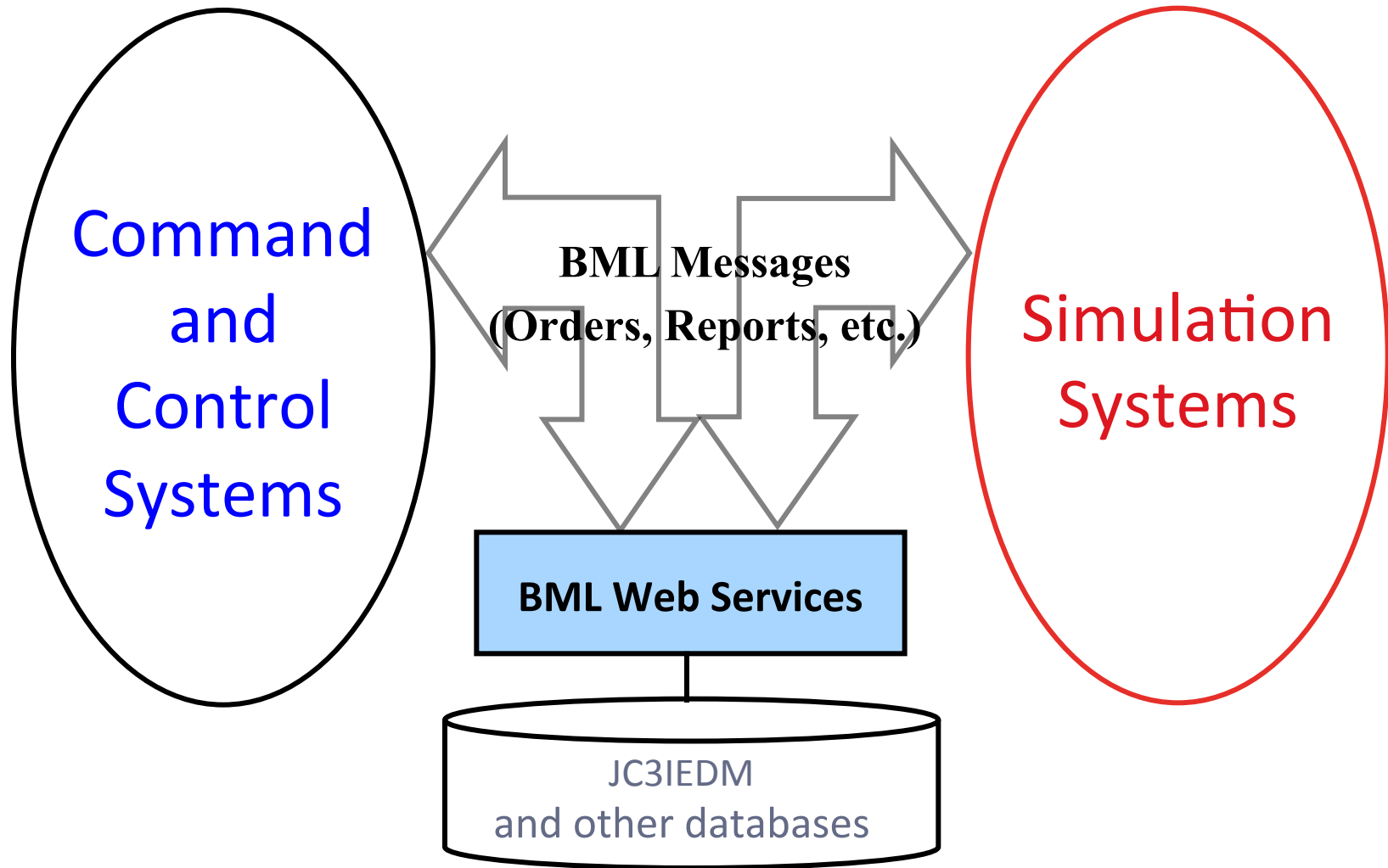

# MSDL/C-BML Convergence 1

- Task Organization definition
  - Also called Order of Battle (ORBAT)
  - Multiple competing formats exist
    - Including MSDL and C-BML
  - MSDL has a standard and implementations
  - C-BML does not address in Phase 1 Standard
    - Could use MSDL standard
  - Alternative: define units in JC3IEDM
- Requirements:
  - Name and type of each unit (including map icon)
  - Identify superior/subordinate unit relationships

# MSDL/C-BML Convergence 2

- Tasking definition
  - Describes actions to be carried out
  - With their interrelations
  - And control measures
- C-BML Phase 1 standard based on MSG-048 experience
  - MSDL has only a placeholder; could use C-BML
- Tactical Graphics: icon and descriptive data
  - Existing MIL STD 2525C and NATO APP-6C are adequate - can support MSDL and C-BML

# Requirements for Combined MSDL/C-BML

- SISO product development groups are working to converge the two standards
- Key distinction:
  - MSDL is for initialization
  - C-BML is for tasking and situational awareness
- Solution: provide a common way to represent military forces that supports both of these
  - Must allow for dynamic change to Task Organization
  - Allow wide range of units and equipment
  - Remain compatible with existing Tactical Graphics standards

# Cross-Referencing Files

- MSDL should not duplicate C-BML tasking
  - Instead, provide reference to C-BML Order document
- C-BML should not duplicate information provided by MSDL
  - e.g. Task Organization and Tactical Graphics
  - Instead, provide reference to MSDL Scenario File
  - New C-BML Phase 1 standard provides an optional place to do this by including a composite for CoordinatingInformation

# Specific Mechanism for Alignment

- Defined across MSDL & C-BML development groups
- Evaluated in simulation federates (e.g. OneSAF)
- MSDL unique identifier that also is usable in C-BML and tactical Graphics
- Used in all C-BML expressions:
  - Orders, follow-on FRAGOs, Tasks, Requests, Reports
- MSDL instance document provides key for all references
- Initial results: approach works well

# BML in NATO

## Modeling and Simulation Group

- MSG has been nexus for BML cooperation
- MSG-048 Technical Activity started 2007
  - Stimulated by US-France project 2006
  - Demonstrations at I/ITSEC 2007 and 2008
  - One-week experimentation 2009 (9 nations)
- MSG-085 Technical Activity started 2010
  - Goal: operational use of MSDL/C-BML (12 nations)
  - Planning demonstration Dec 2013
- Supports trial use of new concepts before standardization

# MSG-048 2009 Architecture

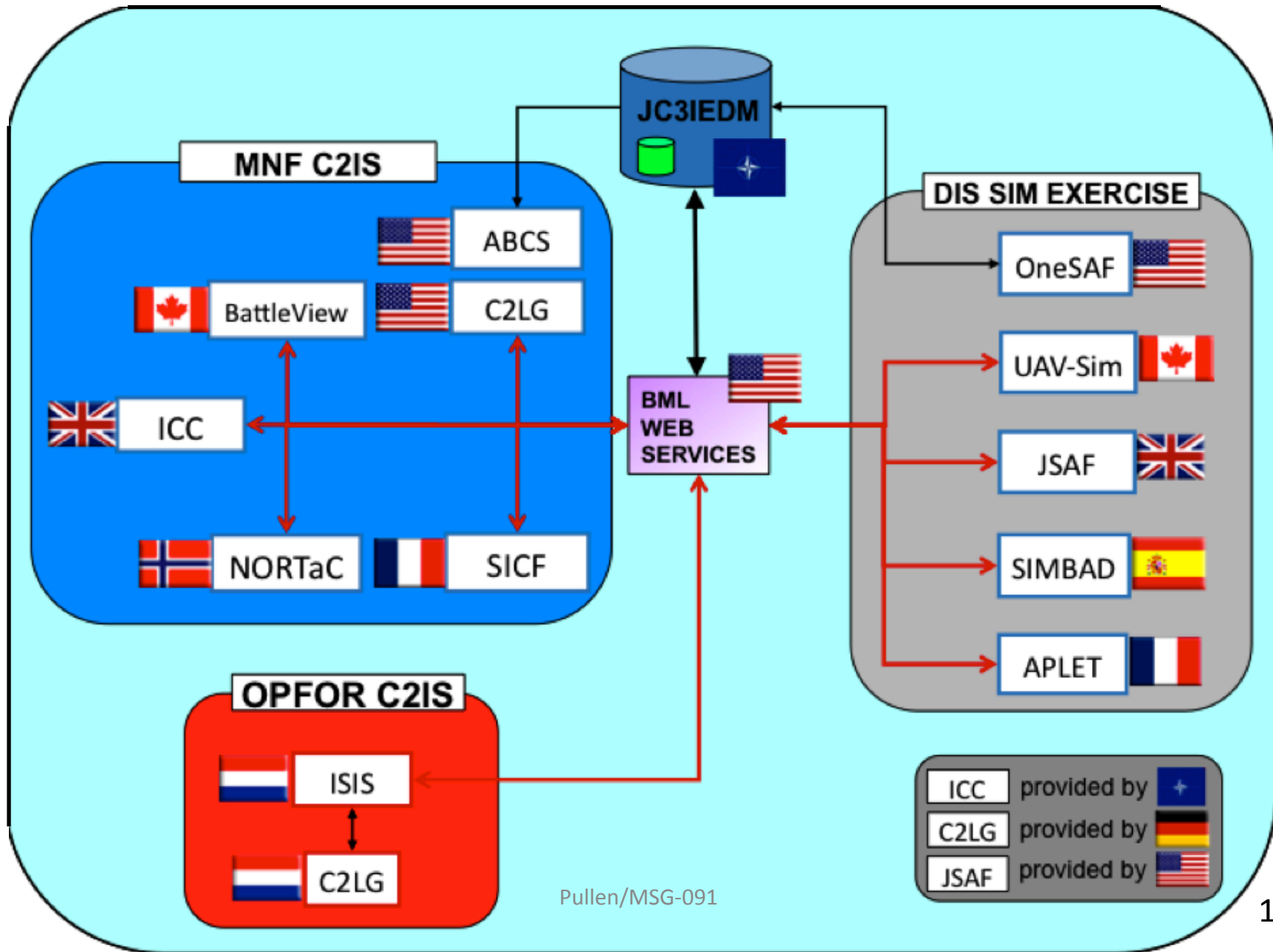

# MSG-085 Mission Statement

*“Assess the **operational relevance** of \*C-BML while contributing to C2-Simulation standardization and assist in increasing the **Technical Readiness Level** of \*C-BML technology to a level consistent with **operational employment** by stakeholders.”*

*\*Including the complementary use of MSDL for initialization*

# MSG-085 Infrastructure Common Interest Group

## I/ITSEC 2012 Air-land Vignette: Sweden, UK & USA

### **Operational Thread and Capability Demonstrated**

- Recce-focused integrated Air-Land vignette using BOGALAND Scenario
  - Ground force Recce cues UAV and fast jet CAS mission
  - Insertion of troops by helicopter
- Enables mission planning, C2 training, and mission rehearsal

### **Technical Capability**

- MSDL/C-BML Infrastructure Information
- MSDL Toolset/Population Mechanism for Preparation and Initialization
- Aggregated MSDL initializes systems
- Scripted BML Server v2.5 bridges multiple schema versions
  - IBML(MSG-048) & SISO C-BML-Light
- Use of WISE Server (SAAB) linked through SBML server and populating 9Land BMS (Swedish C2 system)
- Use of ESRI Track server for Visualization
- Operational C2 systems; ICC and JADOCS integrated JSAF and OneSAF
- WAN-based system

# C2 System: 9LandBMS

# 9LandBMS

- Battalion/Brigade level operational/commercial C2 system
- Used by Swedish forces
- Runs on Windows platform
- Touch interface for field use (wearing gloves)
- Offered to MSG-085 for experimental use
- WISE interface available
  - Used to provide C-BML interface

# WISE MSDL/C-BML SUPPORT

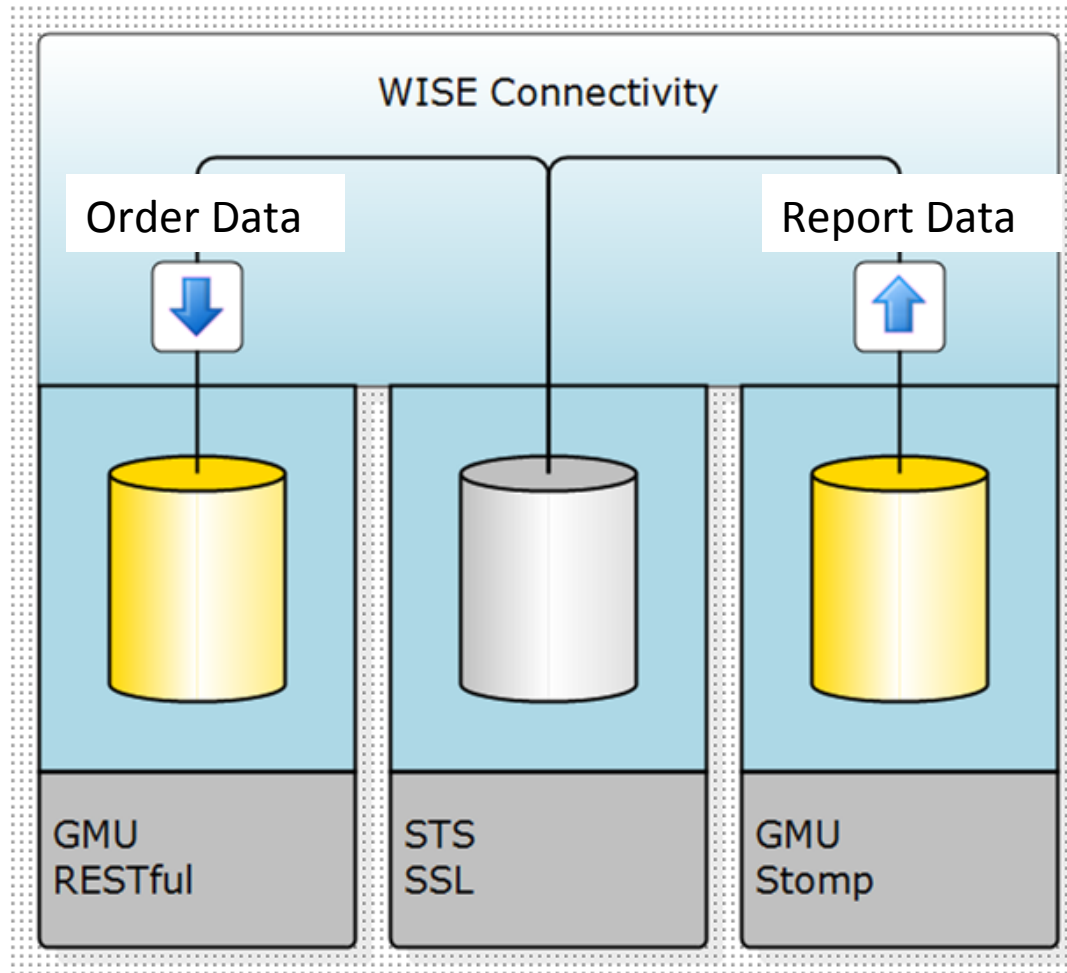

# 9LAND BMS

## WISE SUPPORTED MSDL/C-BML

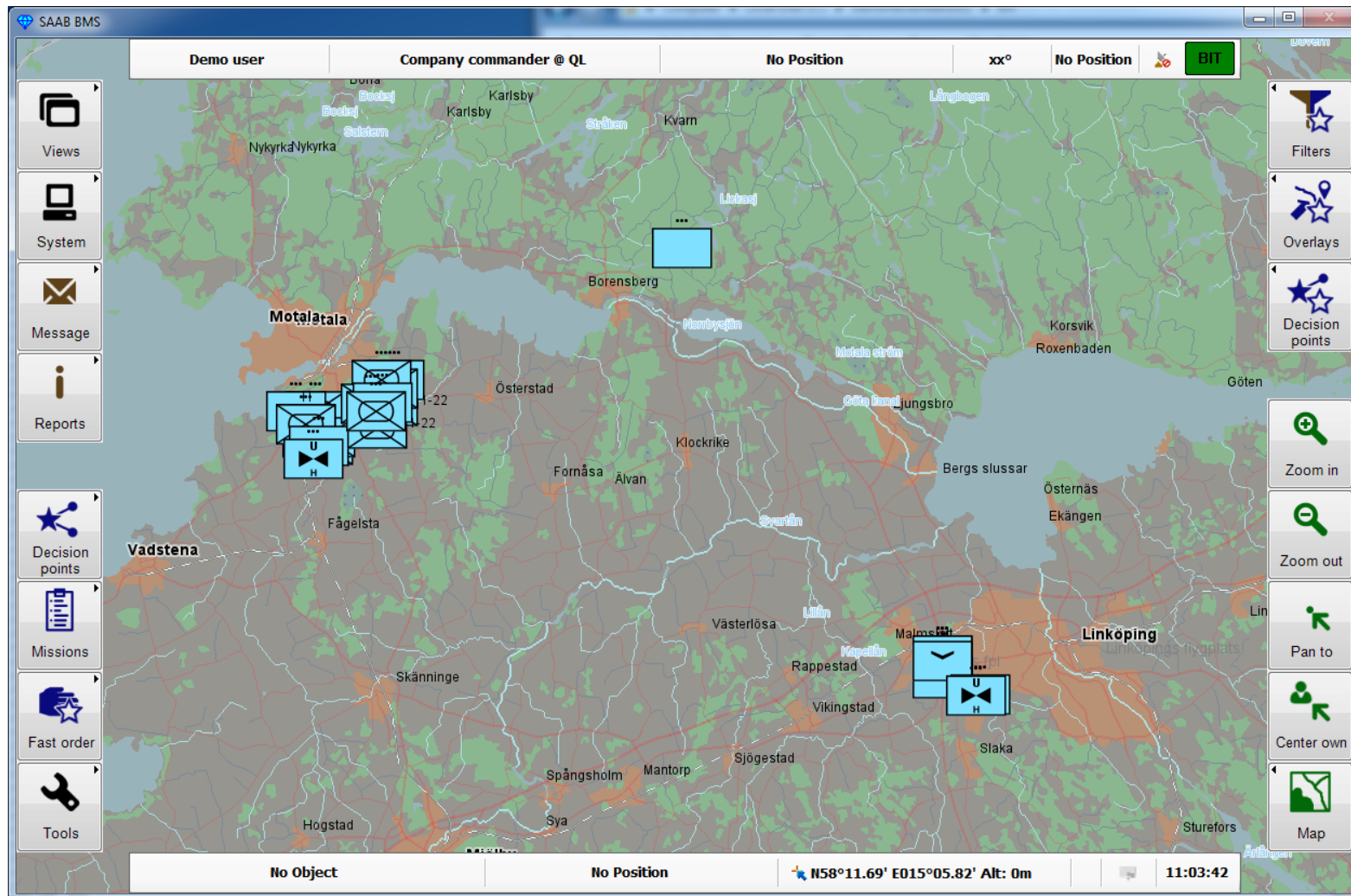

MSDL/C-BML Convergence

13S-SIW-039

# Simulation System: OneSAF

# OneSAF Enhancements for MSDL/C-BML

- MSDL document validation
- Enhanced 2525B symbol code use
- Imports C-BML Full and Light Orders
- Exports C-BML Full and Light Orders from OneSAF Mission Editor
- Works with GMU Coalition Status Monitor
- Send and receive MSDL/C-BML from VMASC CBMS
- References C-BML documents within MSDL files
- Cross-references units and equipment tasking between MSDL and C-BML documents

# MSDL Reference Design Pattern

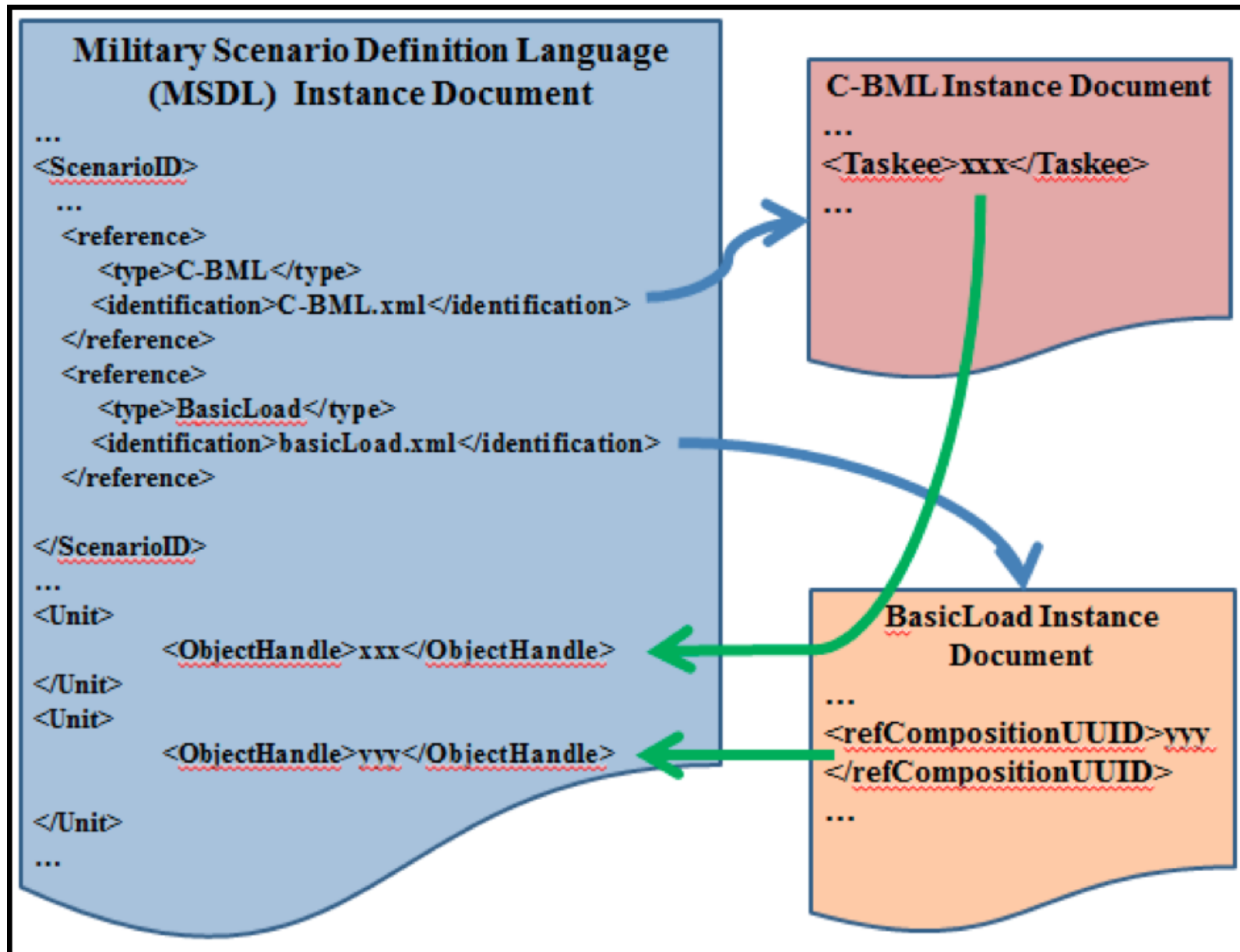

# Server: WISE-SBML

# Coalition C2-Simulation Architecture

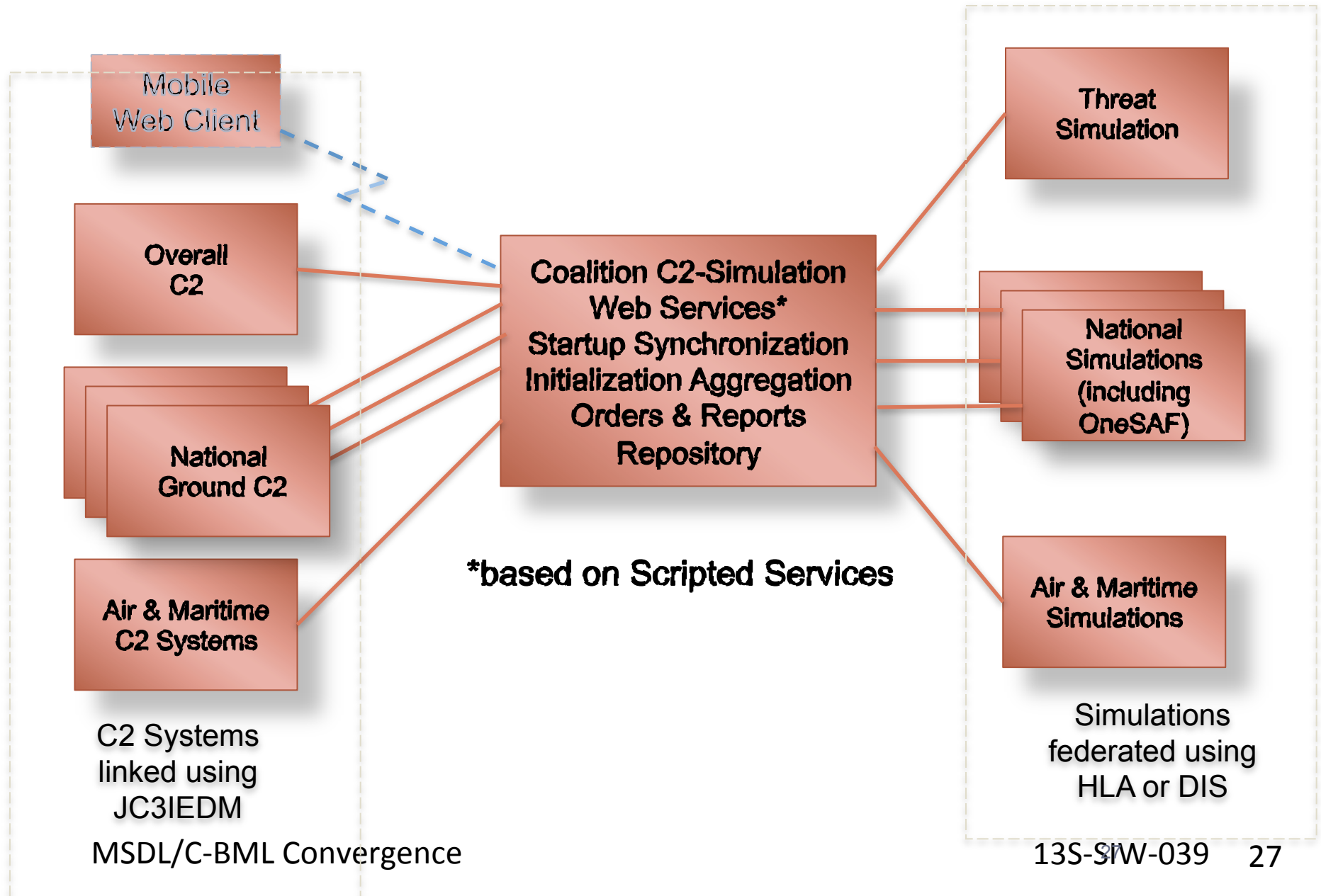

# Scripted BML (SBML) Server

- Created during MSG-048 as open source solution to asynchronous exchange of BML documents (Orders and Reports)
  - Scripted approach allows rapid reconfiguration and reduces errors
- Matured to have a number of features
  - Most important is ability to translate among schemas with same semantic content
- GMU runs a server accessible via Internet
  - Under OpenVPN to avoid hacking
- Demonstrated supporting 10 documents per second
  - Performance reduced under translating feature
- Will remain available open source

# SBML Architecture

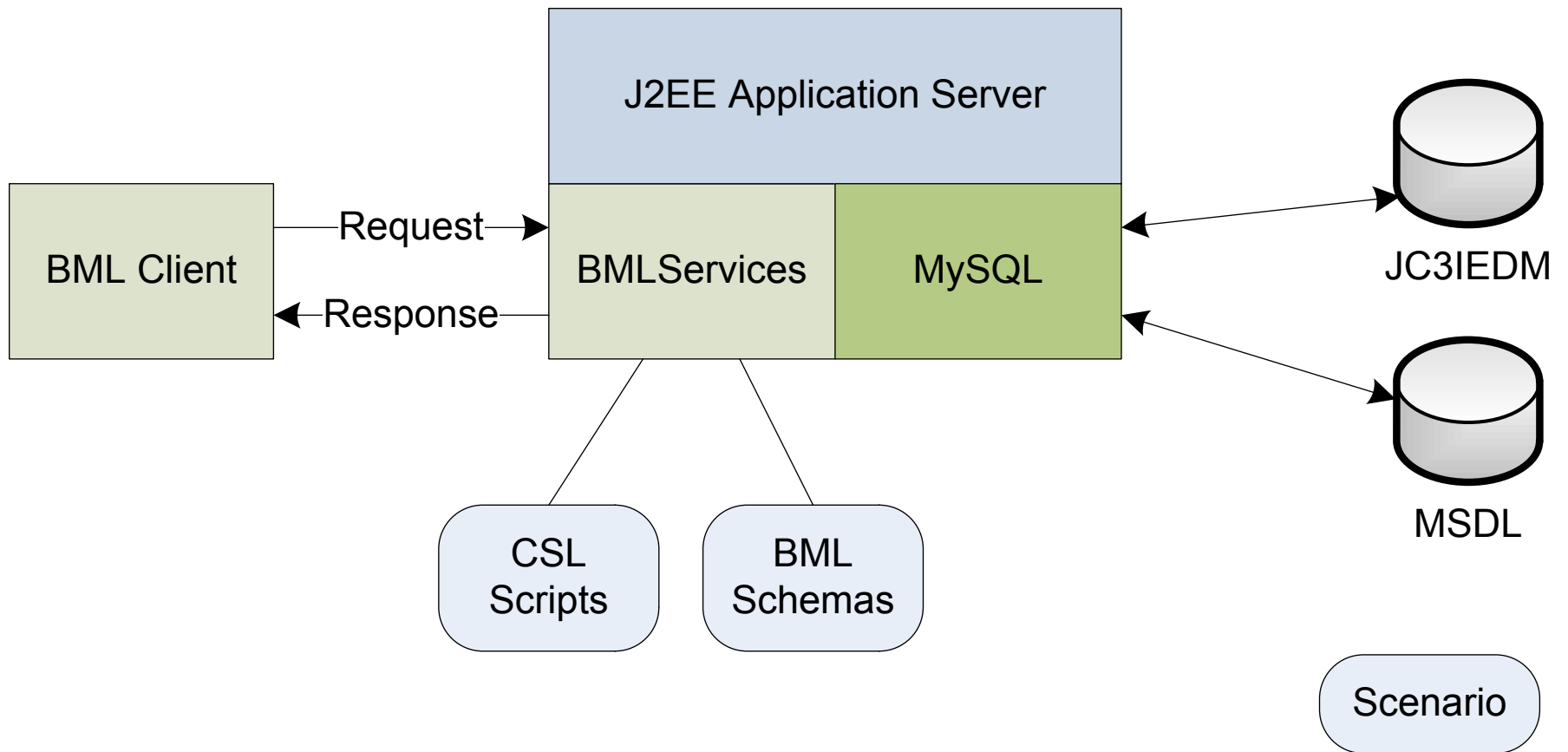

# Adapting SBML to Support MSDL

- When multiple systems participate in a coalition their MSDL files must be merged
- Previously this has been done by hand
- GMU C4I team created a script to do it
  - Required one new script primitive
- Participating systems submit their MSDL prior to initialization
- Server merges it and publishes on command

# MSDL Server Operation

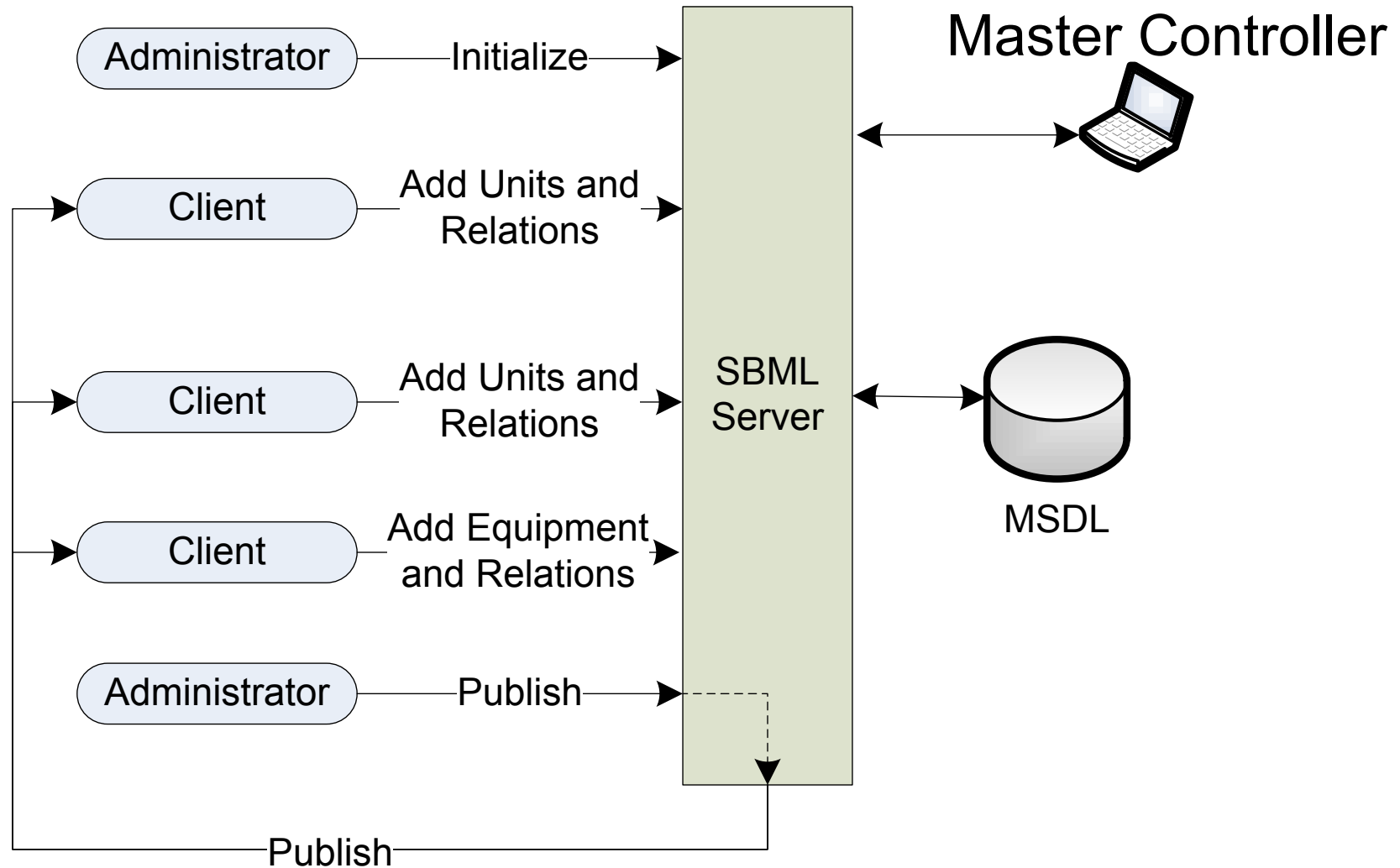

# Evolving SBML to Commercial Infrastructure

- Scripting offers great flexibility
- Open source helps seed BML community growth
- But high-performance, industrially sustained infrastructure is needed for operational use of MSDL/C-BML
- GMU C4I Center and Saab are working together to achieve this

# Saab WISE

- Widely Integrated Systems Environment is a Saab commercial product
  - Aimed at integrating information services (e.g.C2)
- Essentially a very high performance in-memory (non-persistent) database
  - Suitable for cloud environment
- Features a graphic scheme for programming information flows
  - Fills same role as scripting but easier/faster to use
- Saab has offered use of WISE to MSG-085 for use in experimentation

# WISE-SBML

- Saab is supporting GMU fundamental research to show how to use WISE as BML server
  - Open publication and open source components to use with WISE
- GMU has completed prototype high-performance translating server
  - IBML/C-BML with MSDL, like previous SBML
  - Initially C-BML Light but will support compatible C-BML Full
  - Also unparsed/document mode
  - Logging/replay usable to provide persistence
    - (e.g. restart coalition from some point)
- Saab intends to productize this capability
  - Quality assurance and maintenance by Saab developers
- Saab will make non-production WISE-SBML server available to developers on no-cost license
  - Also no-cost evaluation license for production
- GMU will run an instance on Internet over OpenVPN

# WISE-SBML Architecture

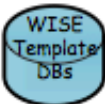
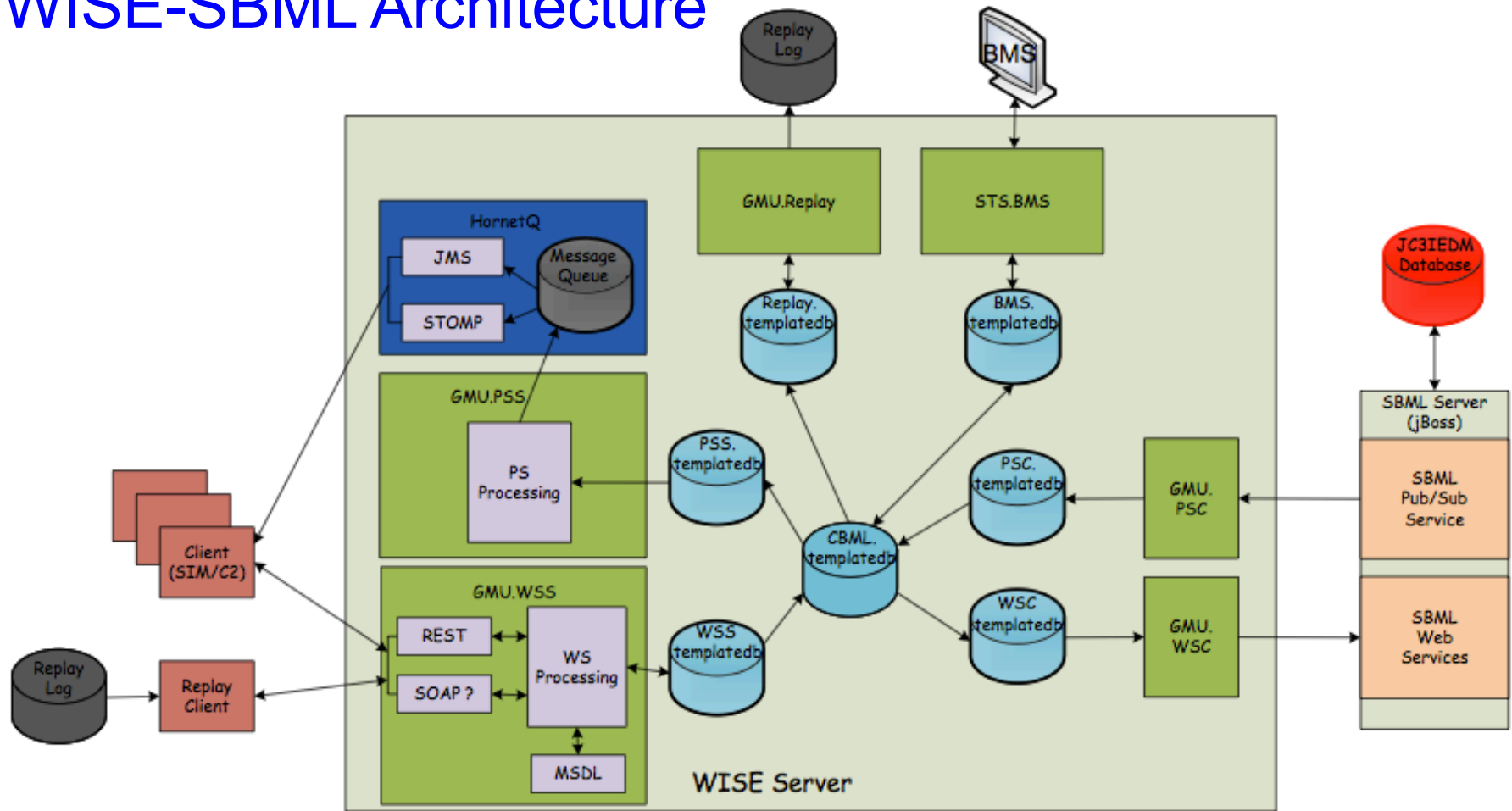

- PSS Publish/Subscriber Server Driver
- WSS Web Services Server Driver
- PSC Publish/Subscriber Client Driver
- WSC Web Services Client Driver
- JMS Java Messaging Service
- STOMP Simple Text Oriented Message Protocol
- REST Representational State Transfer
- BMS SAAB 9LandBMS Battle Management System

# WISE-SBML Closeup

RED BOXES WORKING

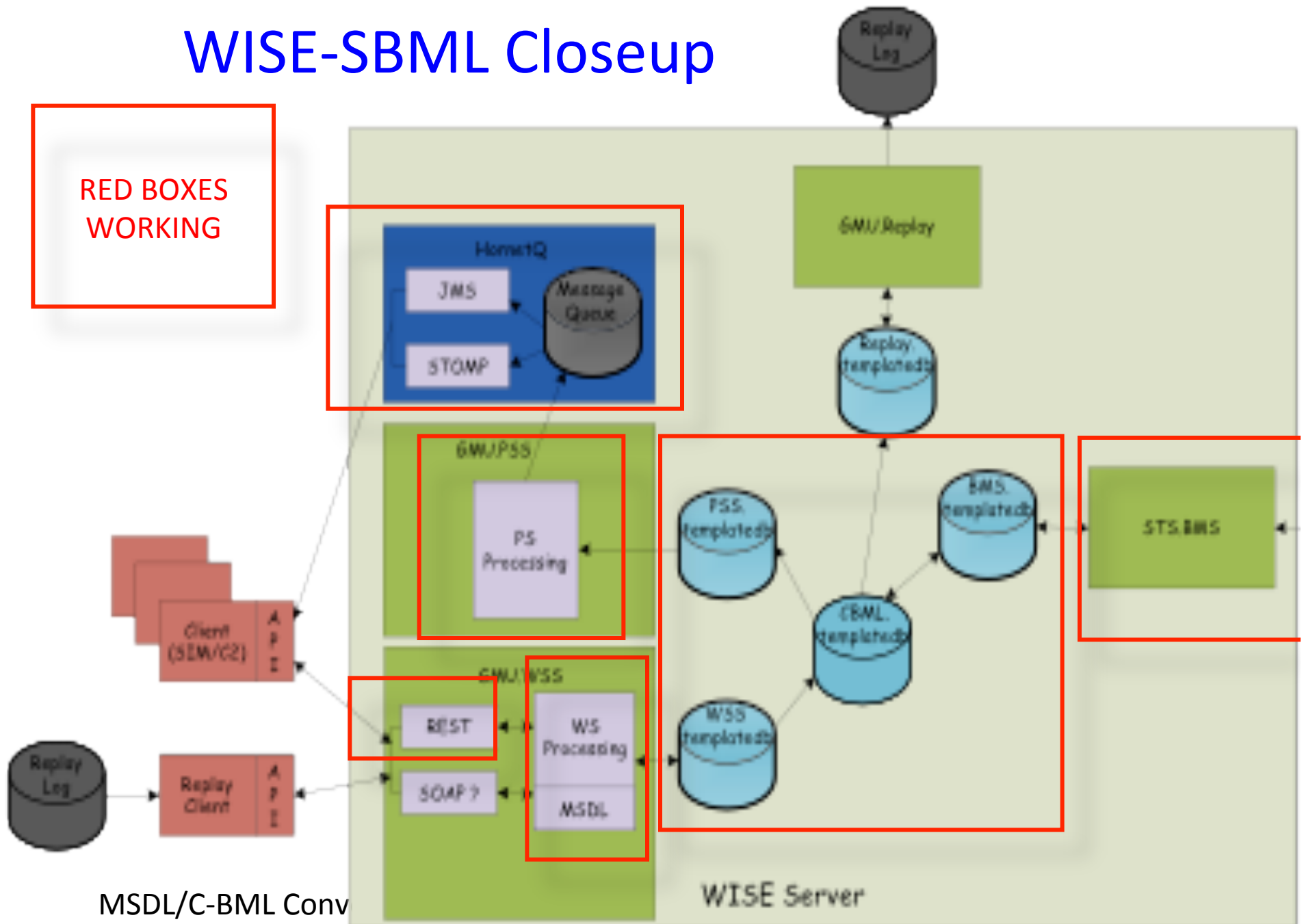

MSDL/C-BML Conv

## WISE-SBML for MSG-085

- WISE-SBML will enable MSG-085 to interoperate all Common Interest Groups using data with shared semantics
  - Regardless of what schema they have implemented
  - Performance projected to be  $> 100$  documents/second
- The hard part of development is done
  - Ready to enter testing phase
  - Also working with Fraunhofer-FKIE to link servers
- Saab also will make WISE-enabled 9LandBMS C2 system available for MSG-085 experimentation

# The Way Forward for MSDL/C-BML

- MSG-085 continues to be a driving force for development of SISO standards
  - I/ITSEC is only one of several activities
  - Final demonstration planned for 2013
- Path to MSDL/C-BML convergence is (mostly) clear
  - Use MSDL Task Organization
  - Use C-BML Tasking
  - Use standard tactical graphics
  - Cross-referenced files and shared unit identifier
- SISO should follow MSG-085 developments closely as indicators for
  - MSDL and C-BML requirements
  - Effective, implementable techniques