

Linked Heterogeneous BML Servers in NATO MSG-085

Dr. Mark Pullen
Douglas Corner
GMU C4I Center
mpullen@c4i.gmu.edu
dcorner@c4i.gmu.edu

Thomas Remmersmann
Dr. Irmtrud Trautwein
Fraunhofer FKIE
thomas.remmersmann@
fkie.fraunhofer.de
irmtrud.trautwein@
fkie.fraunhofer.de

Presentation Overview

- Introduction/overview
- Distributed Servers in MSG-085
- Scripted BML Server
- FKIE Server
- Linking Two Servers
- Conclusions

NOTE: This paper and 13F-SIW-023 are drawn from NATO MSG Symposium 2013 Paper #4 (see references)

Generic BML Architecture

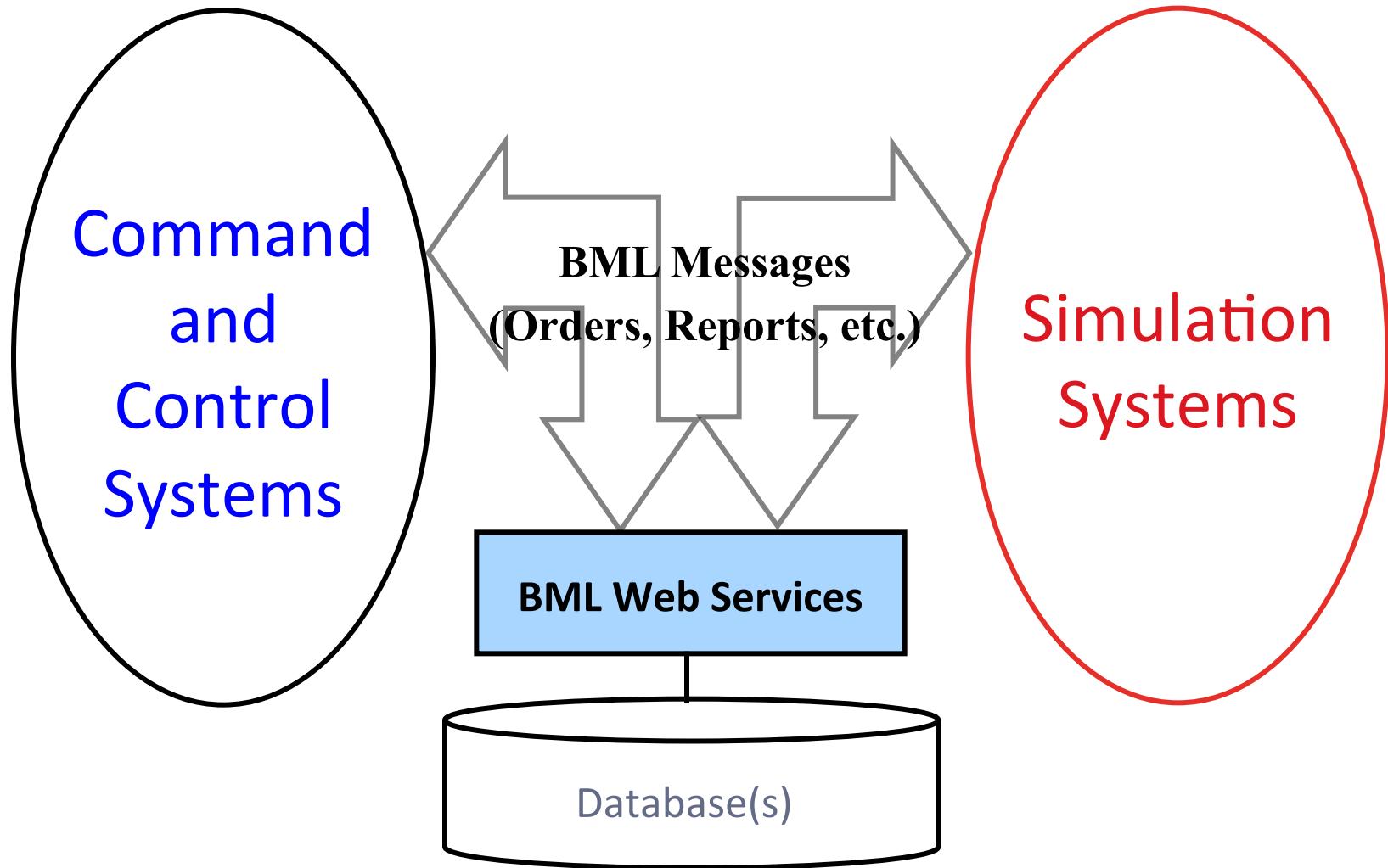

Distributed BML Servers

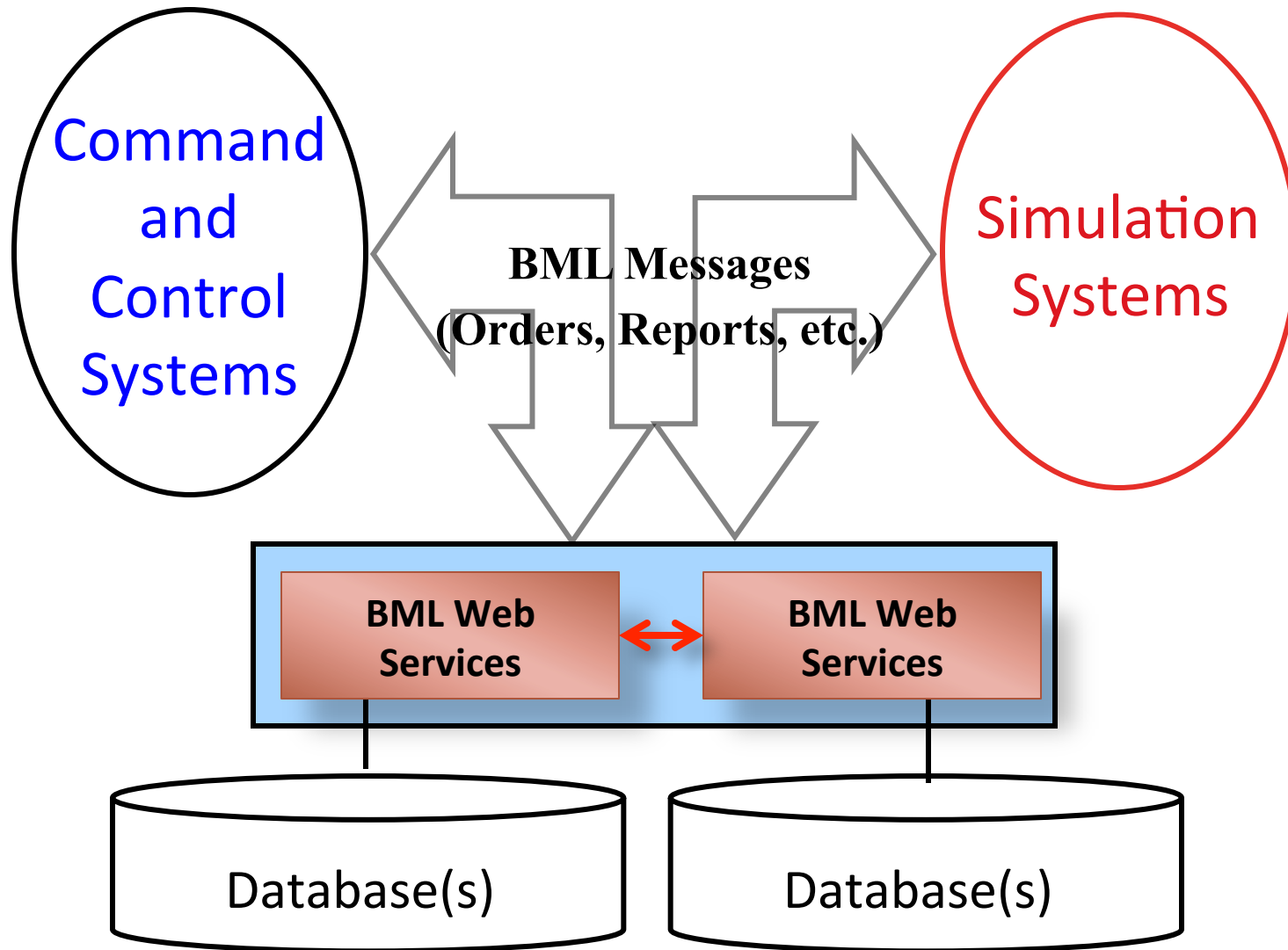

Introduction/Overview

- Overall goal: interoperation of Command and Control (C2) systems with simulations
- Server supports Battle Management Language (BML)
 - Stores XML formatted documents
 - Publishes them to subscribed clients
- Major components:
 - Military Scenario Definition Language (MSDL)
 - Initialization of simulation and C2 systems
 - Coalition Battle Management Language (C-BML)
 - Orders, Requests, and Reports among C2 systems / simulations
 - Building block: Task (who/what/when/where/why) + its status
- Focus of upcoming NATO MSG-085 final demo

Why Distributed Servers

- Geographic distribution
 - Server-client clusters reduce long-haul network traffic
- Parallel operation can improve performance
 - Each server supports part of clients
- Mixed schemata
 - One powerful server acts as translator

BML in NATO

Modeling and Simulation Group

- MSG has been nexus for BML cooperation
- MSG-048 Technical Activity started 2007
 - Stimulated by US-France project 2006
 - Demonstrations at I/ITSEC 2007 and 2008
 - One-week experimentation 2009 (9 nations)
- MSG-085 Technical Activity started 2010
 - Goal: operational use of MSDL/C-BML (12 nations)
 - Planning demonstration Dec 2013
- Supports trial use of new concepts before standardization

MSG-048 2009 Architecture

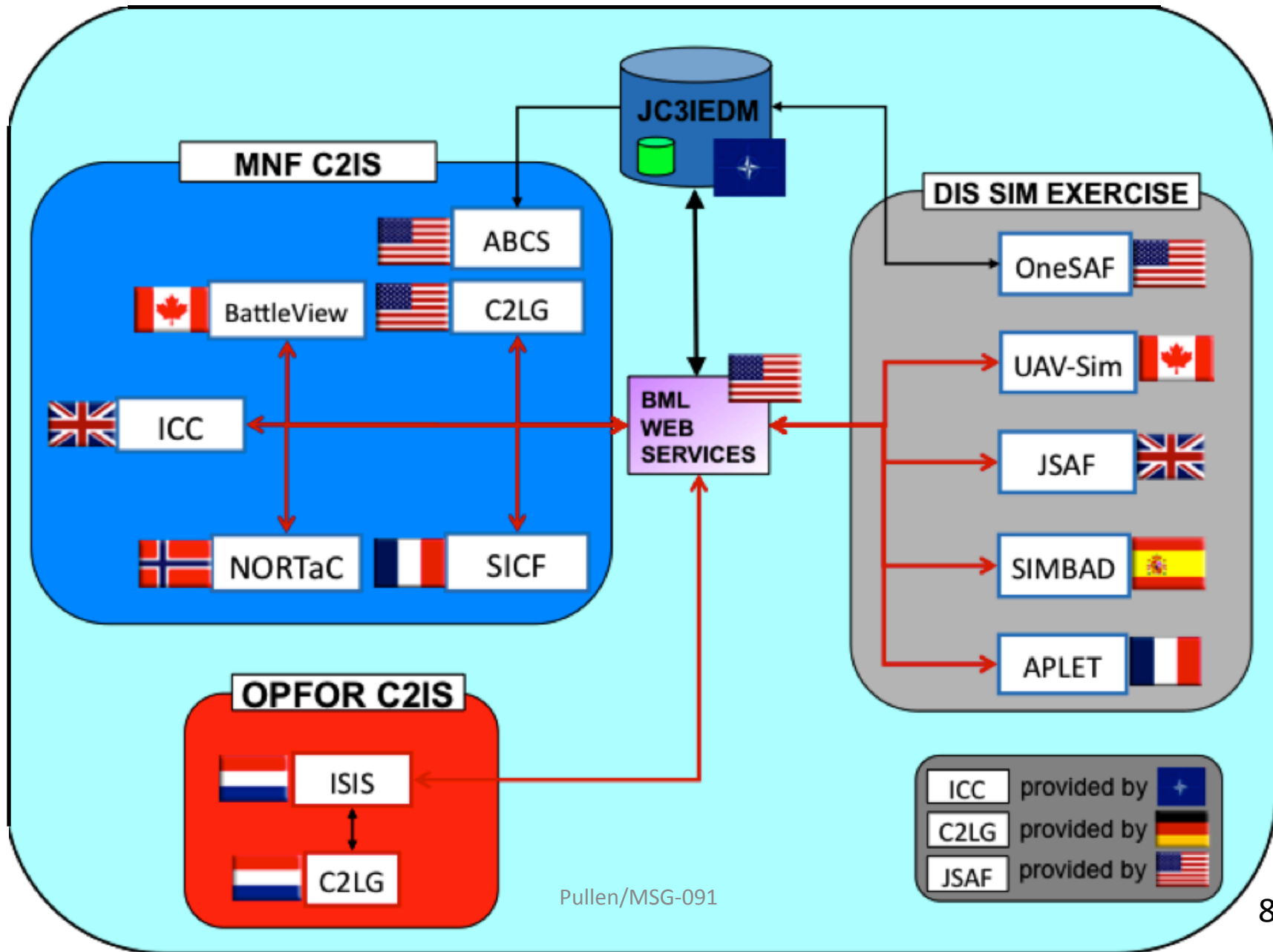

MSG-085 Mission Statement

*“Assess the **operational relevance** of *C-BML while contributing to C2-Simulation standardization and assist in increasing the **Technical Readiness Level** of *C-BML technology to a level consistent with **operational employment** by stakeholders.”*

**Including the complementary use of MSDL for initialization*

MSG-085 Final Demonstration

- Multiple sub-demos with mission planning focus
 - In culminating phase, interoperate as one complex C2-simulation system for mission rehearsal
- Seven nations participating
 - Six C2 systems
 - Four simulations
- Distributed servers
 - FKIE: CIG Land Ops schema
 - WISE-SBML: IBML, C-BML Light, CIG Land Ops
 - Linked via CIG Land Ops

Coalition C2-Simulation Architecture

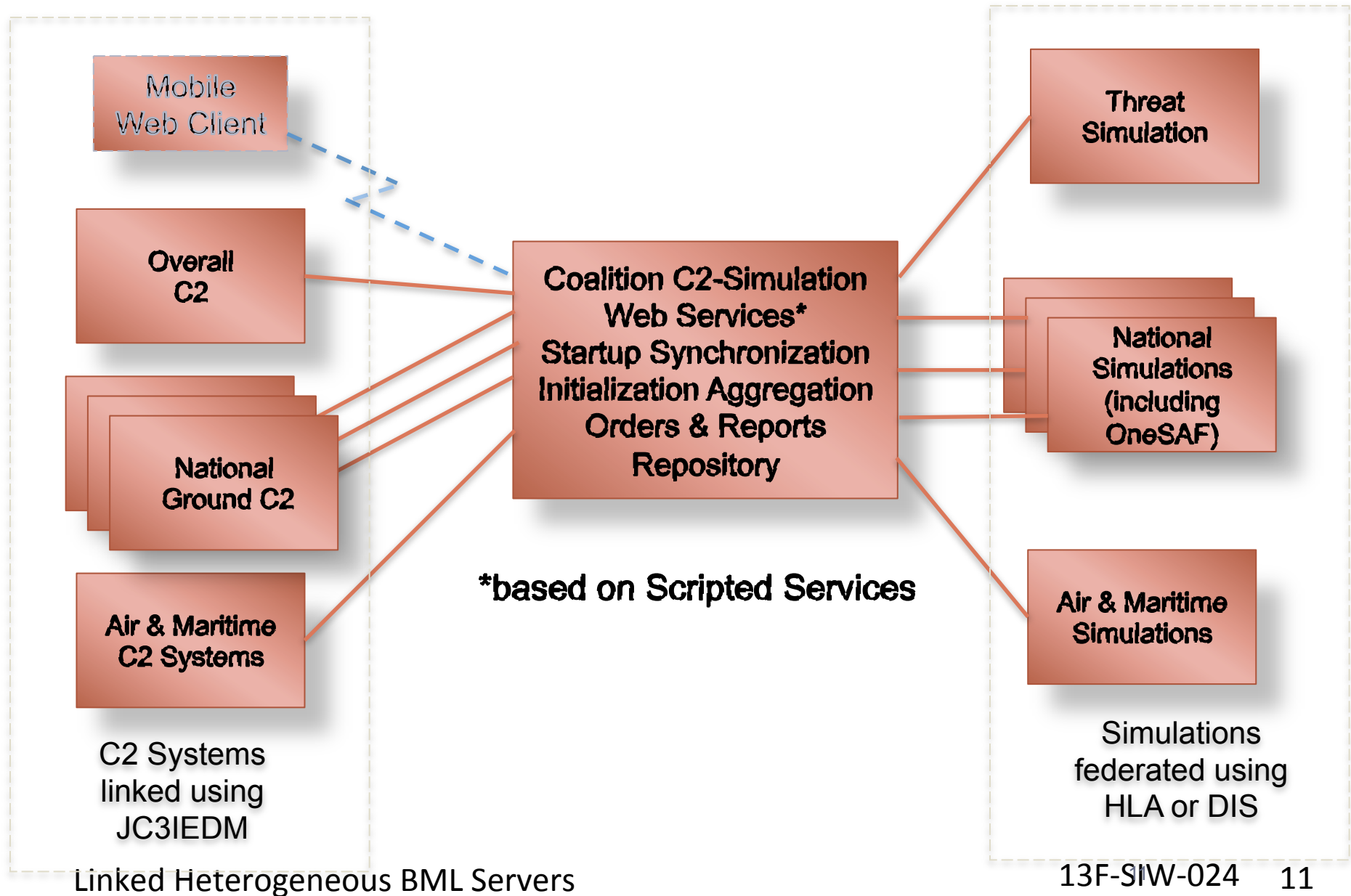

MSG-085 JTF Mission Rehearsal

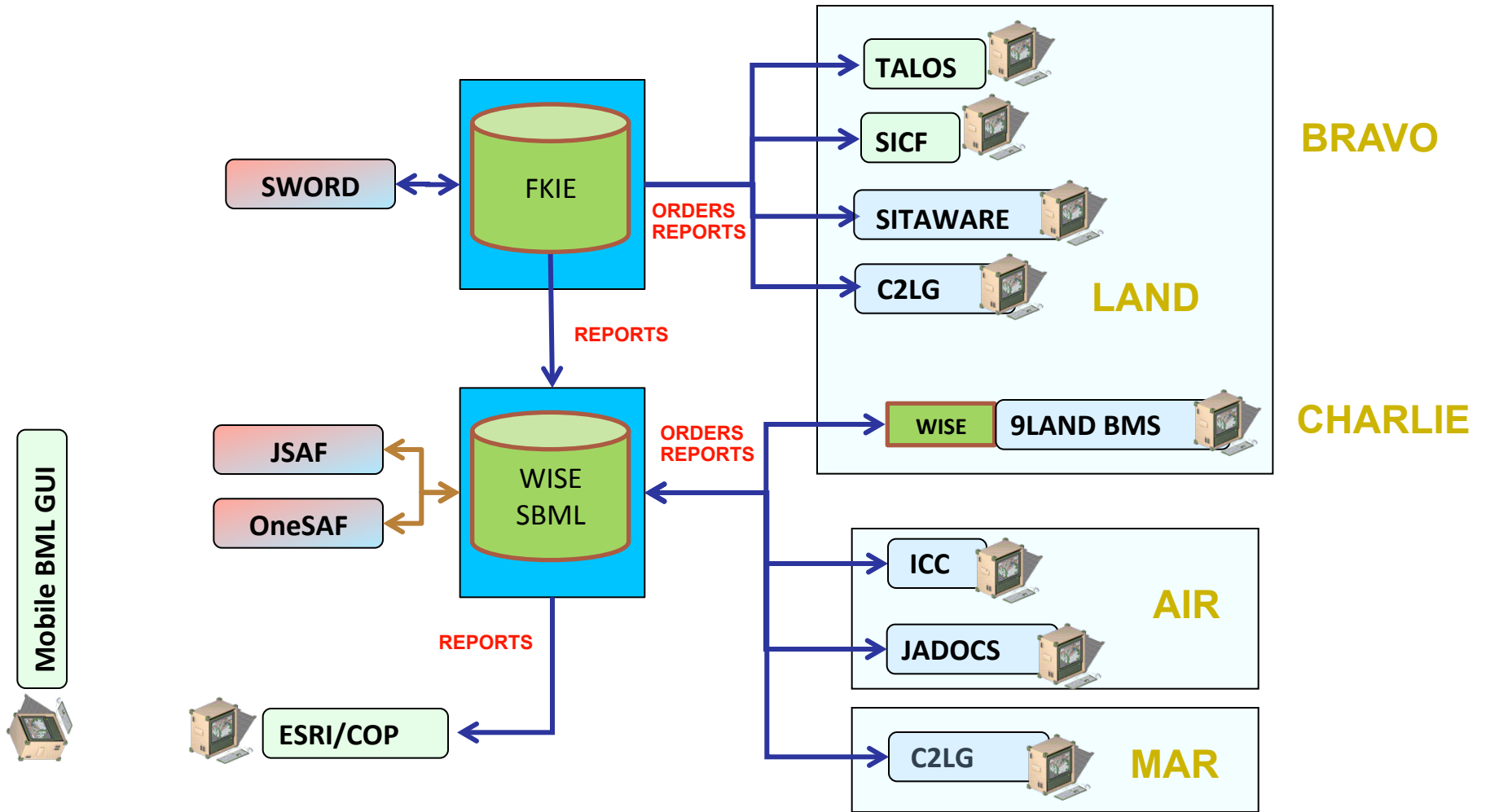

MSG-085 Linked Server Architecture

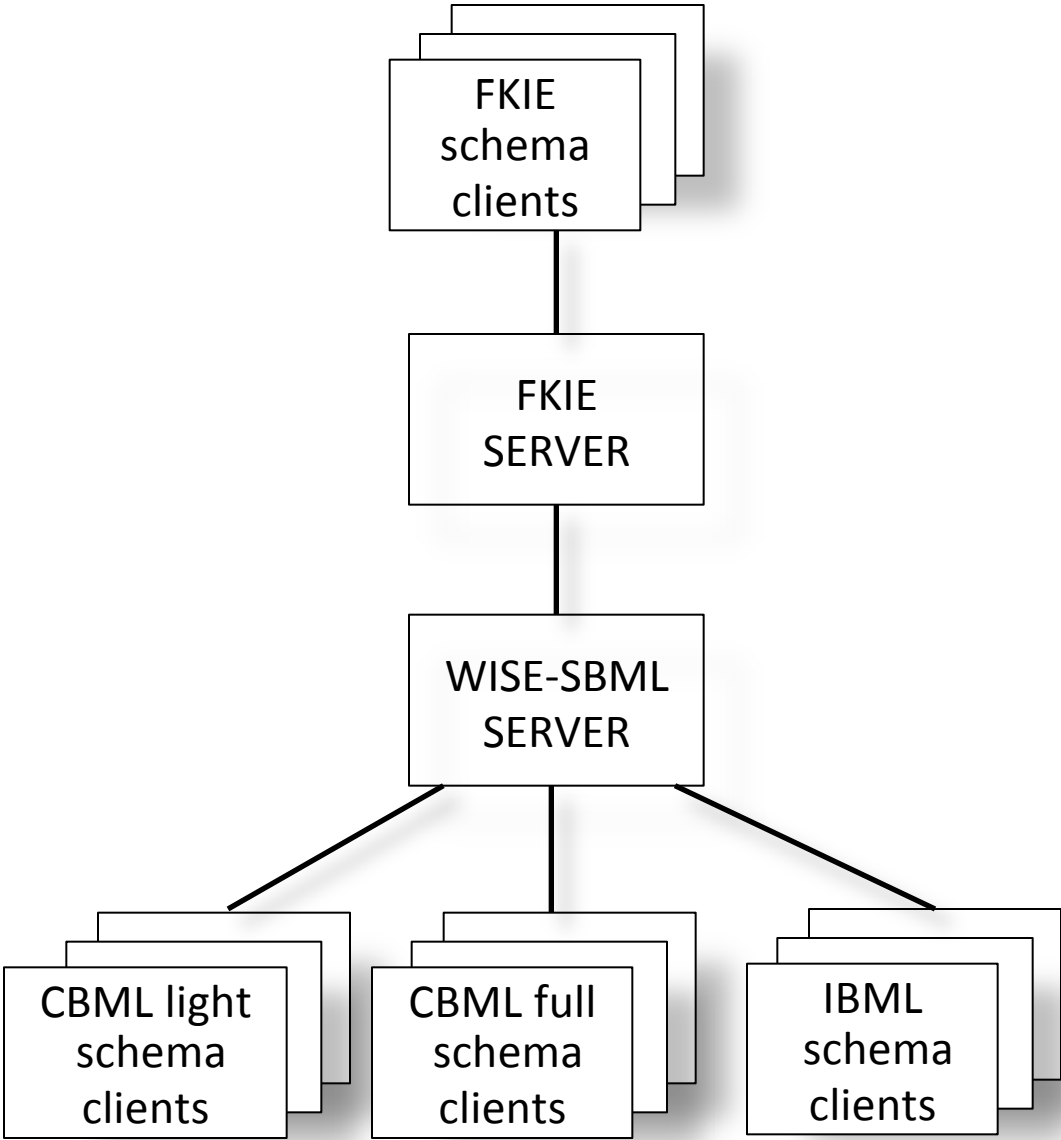

Scripted BML (SBML) Server

- Created during MSG-048 as open source solution to asynchronous exchange of BML documents (Orders and Reports)
 - Scripted approach allows rapid reconfiguration and reduces errors
- Matured to have a number of features
 - Most important is ability to translate among schemas with same semantic content
- GMU runs a server accessible via Internet
 - Under OpenVPN to avoid hacking
- Demonstrated supporting 10 documents per second
 - Performance reduced under translating feature
- Will remain available open source

SBML Architecture

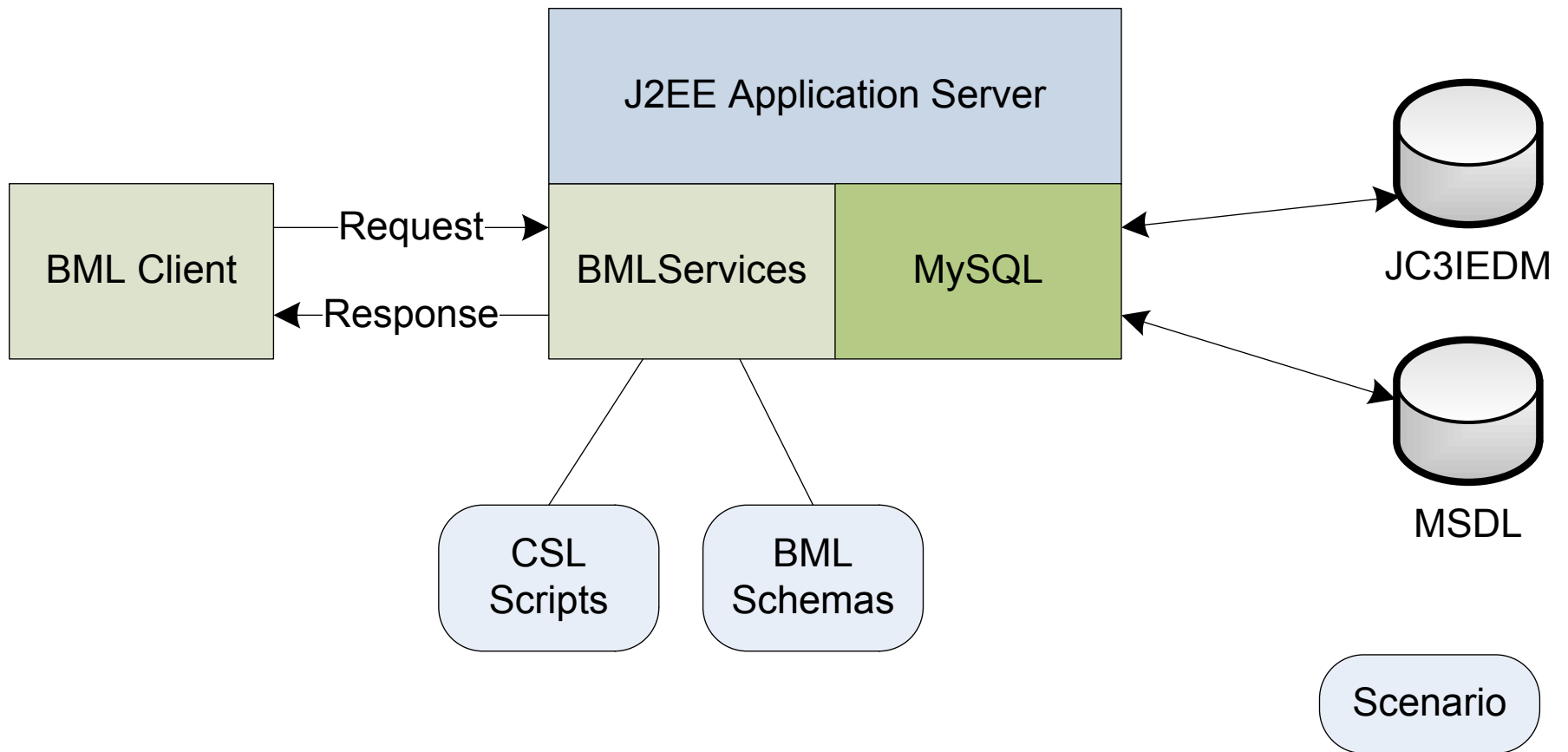

Adapting SBML to Support MSDL

- When multiple systems participate in a coalition their MSDL files must be merged
- Previously this has been done by hand
- GMU C4I team created a script to do it
 - Required one new script primitive
- Participating systems submit their MSDL prior to initialization
- Server merges it and publishes on command

Evolving SBML to Commercial Infrastructure

- Scripting offers great flexibility
- Open source helps seed BML community growth
- But high-performance, industrially sustained infrastructure is needed for operational use of MSDL/C-BML
- GMU C4I Center and Saab are working together to achieve this

Saab WISE

- Widely Integrated Systems Environment is a Saab commercial product
 - Aimed at integrating information services (e.g.C2)
- Essentially a very high performance in-memory (non-persistent) database
 - Suitable for cloud environment
- Features a graphic scheme for programming information flows
 - Fills same role as scripting but easier/faster to use
- Saab has offered use of WISE to MSG-085 for use in experimentation

WISE-SBML

- Saab is supporting GMU fundamental research to show how to use WISE as BML server
 - Open publication and open source components to use with WISE
- GMU has completed prototype high-performance translating server
 - IBML/C-BML with MSDL, like previous SBML
 - MSG-085 CIG Land Ops
 - C-BML Light and compatible C-BML Full
 - Also unparsed/document mode
 - Logging/replay usable to provide persistence
 - (e.g. restart coalition from some point)
- Saab intends to productize this capability
 - Quality assurance and maintenance by Saab developers
 - Will make non-production WISE-SBML server available to developers on no-cost license
 - Also no-cost evaluation license for production
- GMU will run an instance on Internet over OpenVPN

WISE MSDL/C-BML SUPPORT

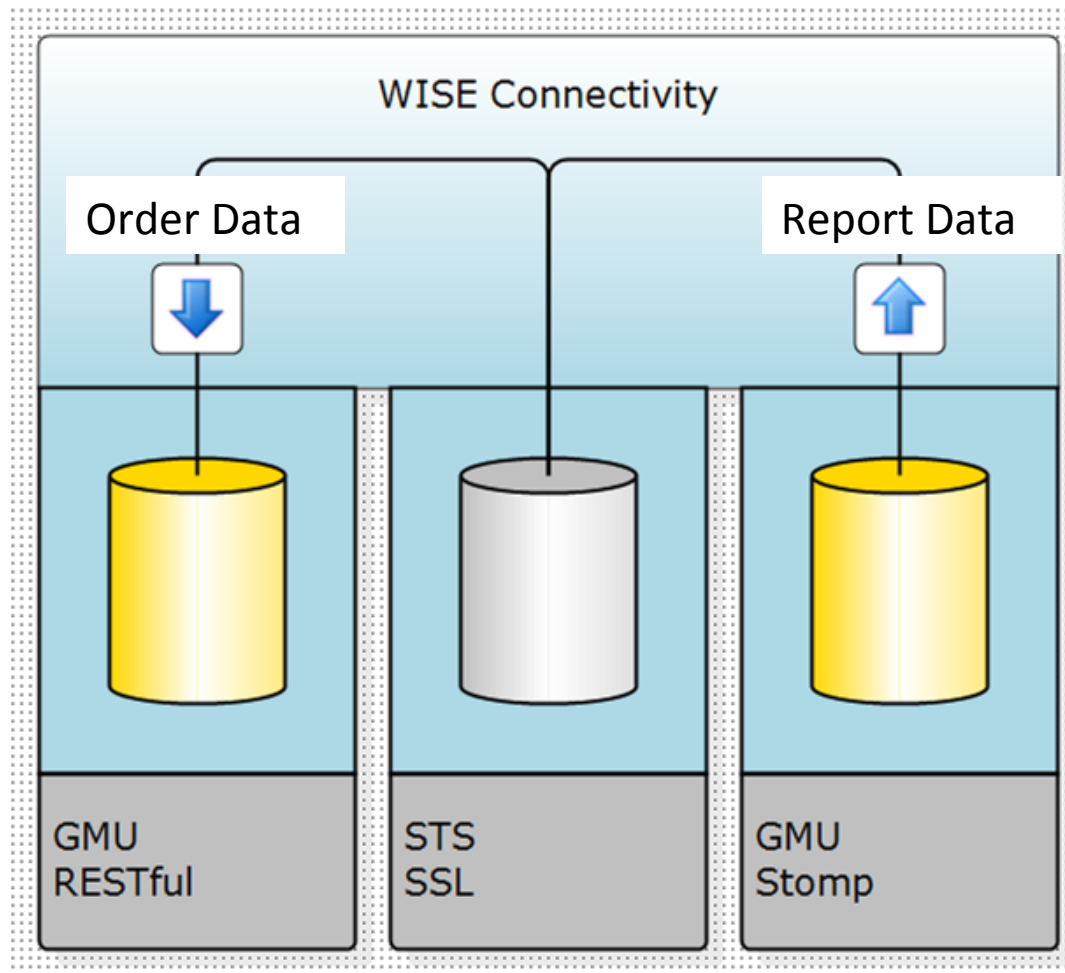

WISE-SBML Architecture

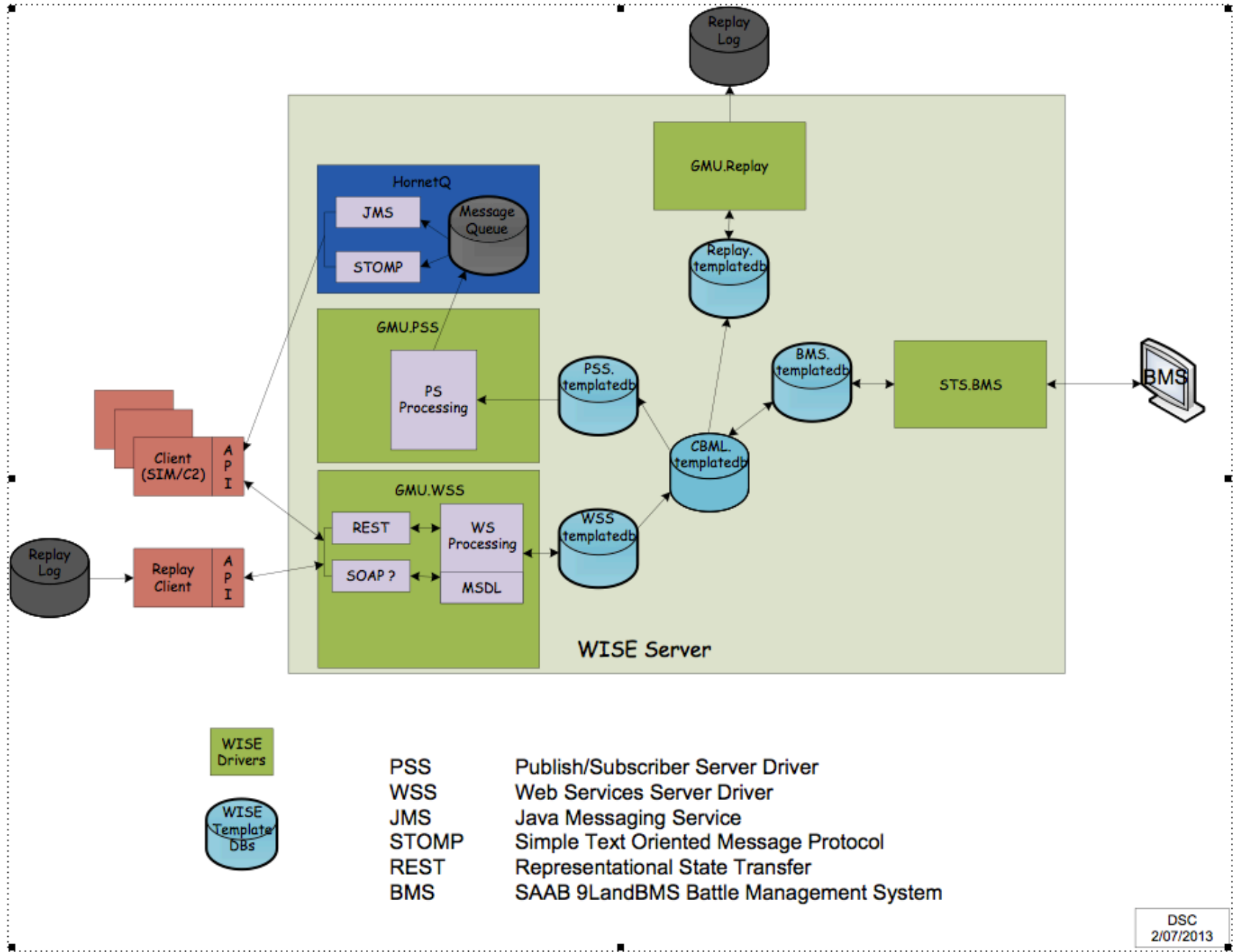

WISE-SBML for MSG-085

- WISE-SBML will enable MSG-085 to interoperate all Common Interest Groups using data with shared semantics
 - Regardless of which schema they have implemented
 - See 13F-SIW-023
 - Performance projected to be ~100 documents/second
- The hard part of development is done
 - Initial testing complete for three schema to be used
 - Completed work with Fraunhofer-FKIE to link servers
- Saab also will make WISE-enabled 9LandBMS C2 system available for MSG-085 experimentation

FKIE BML Server

- Developed as simpler alternative to SBML
 - Simple and fast
 - Retained capability to modify schema
- Input distributed over messaging service
 - Stored in file system for later requests
- XML is not changed or validated by server
 - Limited parsing to extract message type and ID

FKIE BML Server Options Supported

- Currently, supports:
 - IBML (MSG-048 schema)
 - SISO C-BML Phase 1
 - MSG-085 CIG Land Ops
 - MSDL for initialization
- No schema conversion in server
 - All clients must agree on one schema
- Supports same message exchange protocols as SBML
 - Input: SOAP and REST
 - Publication: JMS and STOMP

Linking WISE-SBML and FKIE Servers

- Basis for linking servers:
 - Each listens to the other's STOMP publications
- Thus, server needs to implement client function
 - We did this in a separate Java client
 - Same client implements REST as input to own server
 - Filters based on first-forwarder IP address (parameter in REST header) so messages do not loop
 - Might also choose to filter out some schemata for efficiency
 - We call this a “back to back” (B2B) client
- B2B is started immediately after own server
 - Connects to the other server and starts forwarding

Server Linking Architecture

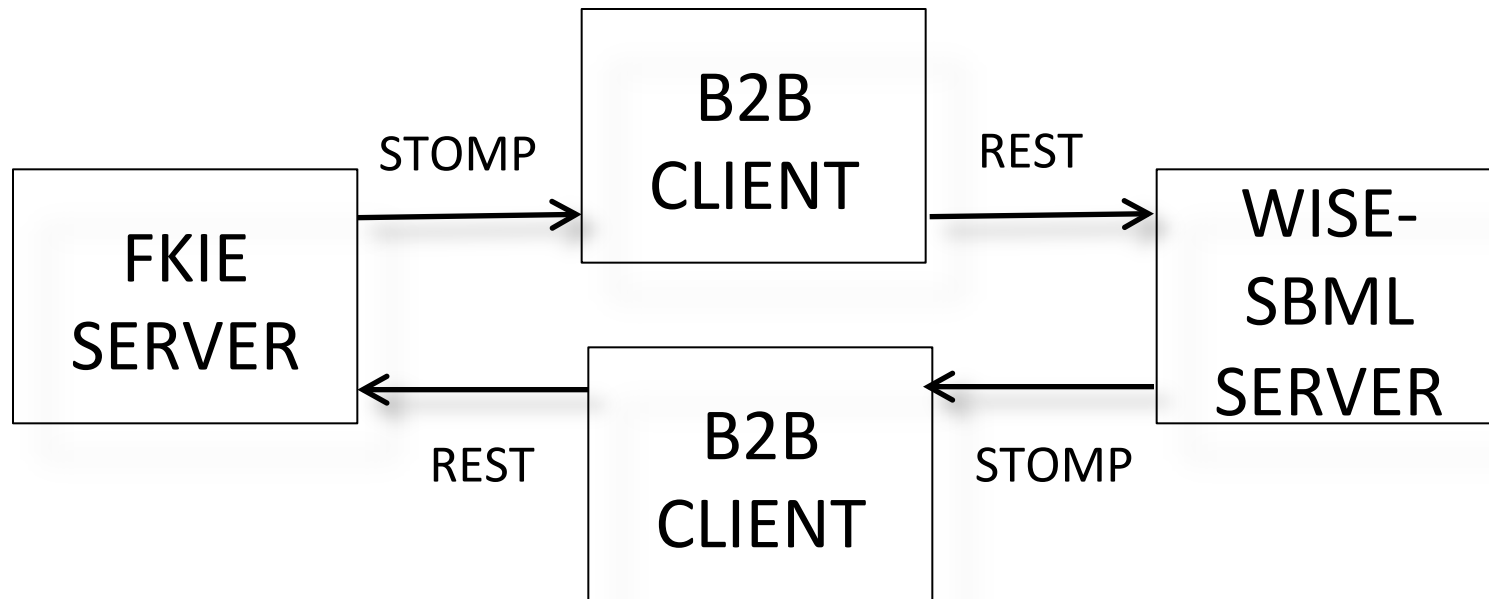

Limitation of Initial Linking Architecture

- Breaking loopback to first forwarder is essential
 - Without this, message would loop forever
- If more than two servers are linked, it becomes necessary to filter out *any* message that has already passed through this server
 - So the simple first forwarder test is insufficient
 - This would require including address of every forwarding server in the message header
 - Or configuring routing information in B2B

Conclusions

- We believe this is the first example of linked heterogeneous BML servers
- Advantages offered suggest it won't be the last
 - Geographic distribution for network efficiency
 - Parallel operation can increase overall performance
 - Hybrid architecture, for example translating servers
- This is only the first step
 - SISO standards should include facilities for linking servers, homogeneous and heterogeneous
 - To simplify future complex system architectures